



COUNTY OF SUTTER
ENCROACHMENT PERMIT
Residential - \$565 / Commercial - \$1921

Development Services Dept.
Engineering Division
1130 Civic Center Blvd
Yuba City, CA 95993
(530) 822-7400
Hours: 8 AM - 5 PM

PERMIT No. _____

Upon completion, submit application to: encroachments@co.sutter.ca.us

Applicant's (Permittee's) Name: _____ Phone: _____

Agency/Firm Name: _____ Email: _____

Mailing Address: _____

Location of Work: _____ APN: _____

Description of Work: _____

SEE APPLICATION INSTRUCTIONS IN THIS PACKET

This encroachment permit is issued on the Applicant's acceptance of all provisions stated herein, including the Special Conditions stated below and the General Conditions of this permit package. It is also understood and agreed by the Applicant that the execution of any work under this permit shall constitute an acceptance of all the provisions stated on this permit. The encroachment permit shall be completed and signed-off prior to requesting a Certificate of Occupancy. Permits are valid for six (6) months. If the work is not completed within 6 months, a new application must be submitted with an additional fee of \$565.00 or \$1921.00.

Applicant: _____

Date: _____

DO NOT WRITE BELOW THIS LINE

24 HOURS IN ADVANCE OF CONSTRUCTION CALL DEVELOPMENT SERVICES DEPARTMENT
ENGINEERING DIVISION AT (530) 822-7400

Special Conditions: _____

Permit Expires: _____ Approved by: _____ Date: _____

ROAD COMMISSIONER

Inspector's Comments: _____

Date: _____

Permit Fees: _____ Received By: _____ Date: _____ Receipt: _____

This permit shall be available at the job site at all times while the work is being performed.

GENERAL PROVISIONS

1. The permittee shall defend and hold the County and/or County's representative harmless from and against any liability that arises in any way from the work of this permit.
2. At least two (2) working days before beginning work, permittee or his contractor shall contact the Underground Service Alert (USA) at 811 to notify utility companies to mark or indicate the location of their utilities. The marked location should be considered as being approximate only.
3. This installation/work in the County's Right of Way (or Public Utility Easement) is for the sole use of the permittee and applies to permittee's personnel and equipment, as well as private contract workers and their equipment, when directly supervised by permittee's representatives. All future maintenance, repair, replacement, or upgrade, including its effect on roadway cross section, pavement and shoulder is at the permittee's expense.
4. It is the responsibility of the permittee to determine the location of the right of way prior to construction.
5. At least one lane of travel shall be kept open for the general public at all times. Road closures shall not occur without separate written approval of the Road Commissioner.
6. All work shall conform to the applicable sections of the current edition of the Sutter County Improvement Standards and the applicable sections of the current edition of State of California Department of Transportation Standard Specifications and Standard Plans. All work shall be subject to the inspection and entire satisfaction of the Road Commissioner or his authorized agent(s). Any existing facilities or utilities that are damaged or disturbed shall be replaced or repaired at permittee's expense.
7. For all work done under this permit, the Sutter County Development Services Department must be notified as soon as possible at 530-822-7400. Appropriate agencies shall be contacted and/or notified of work by permittee prior to any work. If work affects adjacent property owners, permission must be secured prior to starting work. Nothing in this paragraph is intended to state or imply that the County shall be enforcing any term or condition placed upon the permittee by any other agency. The sole obligation created by this provision is the obligation to contact and notify any appropriate agency.
8. The permittee shall comply with all regulations and/or permits for storm water regulations through the Regional Water Quality Control Board of the State of California. Nothing in this paragraph is intended to state or imply that the County shall be enforcing any term or condition placed upon the permittee by the Regional Water Quality Control Board of the State of California. Enforcement of any term or condition shall be the sole responsibility of the Regional Water Quality Control Board.
9. **SURFACE RESTORATION** - Trench restoration and compaction shall be per Sutter County Standards Detail H-28. Areas within five feet of edge of pavement shall have 4" Class II AB (rock) placed back over compacted backfill.
10. **BACKFILLING** – Where any excavation is made in a roadway or shoulder, the excavation shall be replaced with suitable material properly backfilled and tamped so that the backfill shall be even with the surrounding surface and maintained at such level until final settlement has taken place. (See County Details H-28 & H-29A)
11. **PAVEMENT** – Where any concrete, macadam or other pavement is disturbed or broken, it shall be replaced with asphalt concrete pavement or Type A concrete, at the existing grade and cross-section set forth in the County Detail H-12.
12. **BRIDGES, CULVERTS OR OTHER STRUCTURES** – Where structures cross the roadway, they shall conform to the grade and cross-section of the roadway as officially laid out. The grade and cross-section of the waterway shall conform to the official line thereof, or otherwise so as not to obstruct the flow in the natural channel. Structures alongside the roadway shall also conform to the provisions of this paragraph and shall provide for easy access to and from the highway.
13. **PIPES, CONDUITS, ETC.** – Where service pipes are to cross the roadway, the connections shall be made without disturbing the asphalt concrete pavement, wherever possible, by boring the pipes under the pavement. No open cut in asphalt unless there is no other alternative to cutting asphalt to do work. Minimum 36" cover is required over all lines placed in the right of way, including drainage ditches and irrigation ditches where crossed.

14. **TREES** – In the erection of pole lines, unless otherwise herein provided, no trees located in the right of way shall be cut or trimmed unless authorized by the Road Commissioner.
15. **PROTECTION OF TRAFFIC** – During the progress of the work, such barriers shall be erected and maintained as may be necessary for the protection of the traveling public; the same shall be properly lighted at night; and the permittee shall be responsible for all damages to persons or property due to or resulting from any work done under this permit. Road safety procedures shall conform to the Manual of Traffic Control for Construction and Maintenance Work Zones (Caltrans Manual).
16. **DRAINAGE** – No work shall be done on the roadway that interferes with its drainage. All ditches must be kept open to the unrestricted flow of water according to the official or natural grade and cross-section. Irrigation water must not be allowed to flow to or stand in the roadside ditches along the roadway. Existing drainage shall not be impaired by the replaced structure(s), and permittee agrees to future cleaning of structure(s). The permittee shall retain all additional water resulting from the work on site. No additional runoff shall be directed onto the County right of way.
17. **CLEANING UP** – All rubbish, debris, and excess materials shall be removed from the right of way and the vicinity left in a neat condition satisfactory to the Road Commissioner. All excess materials shall be removed from County right of way and hauled off site.
18. **MAINTENANCE** – All pavements and roadside structures, etc. shall be maintained in proper condition for the free use of traffic in the vicinity of the worksite. New work or replacements shall be maintained in proper condition until final settlement has taken place, and any defects of workmanship or construction shall be immediately repaired or replaced to the satisfaction of the Road Commissioner. Permittee replaced culverts will be kept free from flow impediments (see Drainage above).
19. **ALTERATIONS AND CHANGES** – The Road Commissioner reserves the right to order any changes of terms, conditions and restrictions governing this permit that in his opinion may conflict with the proper construction and maintenance of the County roadway system, and he may alter or change the type or method of doing any of the work under this permit due to unforeseen conditions.
20. **RELOCATION OR REMOVAL OF ENCROACHMENT** - Pursuant to the Streets and Highways Code, Section 1463 under permit provisions, relocation or removal of encroachments and facilities: Public utilities may be required, within a reasonable time, to relocate such of their facilities as interfere with an enlarged public use of the highway, except in those cases where the enlarged use of the highway involves a state freeway. All permits other than those issued to public agencies or a public utility, having lawful authority to occupy the highways, are revocable on five days notice and the encroachment must be removed or relocated as may be specified by the Road Commissioner in the notice revoking the permit and within a reasonable time specified by the Road Commissioner unless the permit provides a specified time.



COUNTY OF SUTTER ENCROACHMENT PERMIT

INSTRUCTIONS

Development Services Dept.
Engineering Division
1130 Civic Center Blvd
Yuba City, CA 95993
(530) 822-7400
Hours: 8 AM - 5 PM

Upon completion, submit application to: encroachments@co.sutter.ca.us

Any work or improvements that are to be performed adjacent to a County Maintained Roadway require review by the County and issuance of a Permit to Encroach on the County Road Right of Way. Any work done in the County Right of Way by an applicant or his designated contractor prior to issuance of an encroachment permit is subject to removal and reconstruction in compliance with the terms of the Encroachment Permit at the owners expense.

In order to review an application for an encroachment permit the following items are to be submitted:

1. All work to be performed as part of the encroachment permit is required to be done by a Licensed Contractor holding a valid Contractors License in one of the following classifications as applicable to the work to be performed:
 - A – General Engineering
 - B – General Building
 - C-8 – Concrete
 - C-12 – Earthwork and Paving
 - C-27 – Landscaping
 - C-32 – Parking and Highway Improvements
 - C-34 – Pipeline

Provide Contractors Name, Business Address and License Number prior to work beginning.

2. A site plan on 8.5x11 or 11x17 paper showing the Existing Conditions of the property. Existing Conditions including the following items, but are not limited to these items:
 - Existing structures (house, mobile home, barns, out buildings, etc.)
 - Existing driveways or paved areas
 - Existing culvert pipes or drainage structures (include the size of the pipe or structure)
 - Existing drainage ditches
3. Proposed Improvements in the County Road Right of Way shall be shown on the site plan with all applicable dimensions needed to define the limits of the work. Proposed Improvements including the following but are not limited to these items:
 - Driveway aprons (Only the portion in the County Right of Way)
 - Paving (Asphalt or Concrete)
 - Culvert pipes – acceptable pipe materials are as follows:
 - Reinforced Concrete Pipe (RCP)
 - Corrugated Metal Pipe (CMP)
 - C900/905 Plastic Pipe
 - HDPE Pipe
 - Ductile Iron Pipe
 - Landscaping
 - Utility Undergrounding
 - Fencing
 - Signage

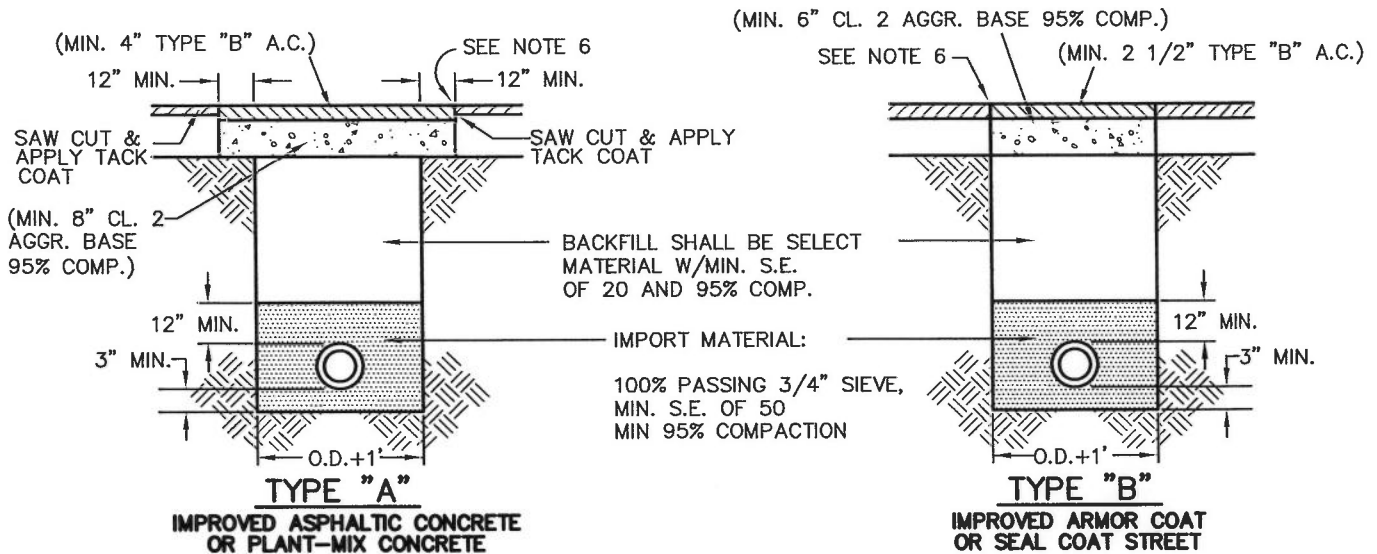
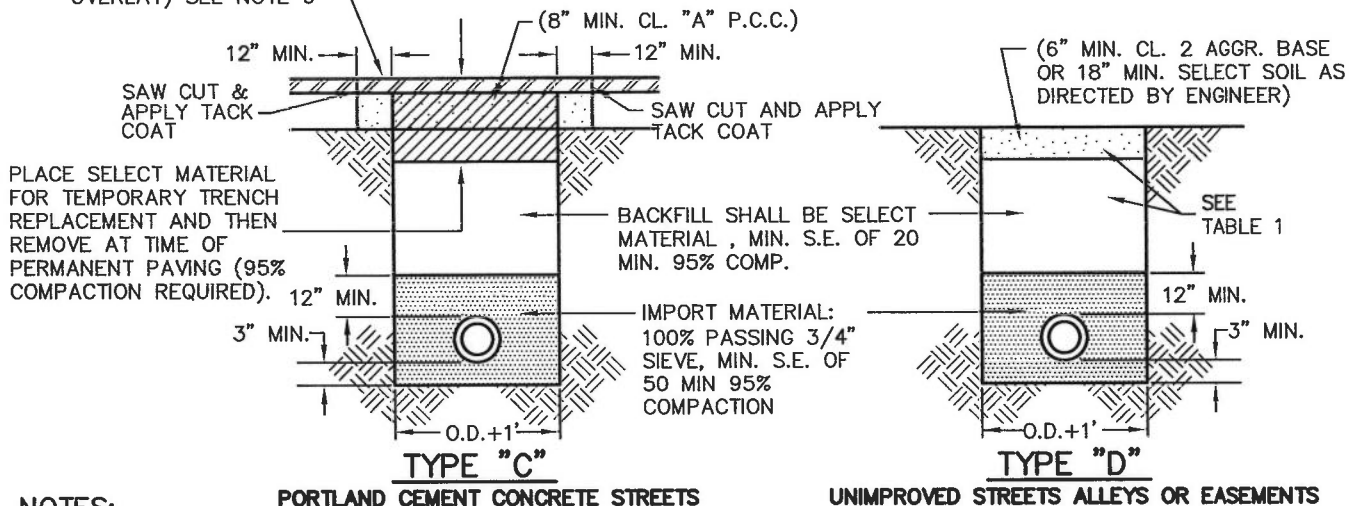

TABLE 1

TYPE	LOCATION	BACKFILL & COMP.	RESTORATION TYPE
D-1	WITHIN 5' OF E.P.	SELECT MATERIAL 95%	6" CL. 2" A.B.
D-2	GREATER THAN 5' TO E.P.	SELECT MATERIAL 90%	18" MIN. SELECT SOIL
D-(SW)	SIDEWALK AREAS	SELECT MATERIAL 95%	4" P.C.C. OR EQUAL TO EXIST. WHICHEVER IS GREATER

(PLACE TYPE "B" A.C. IF PAVEMENT HAS AN A.C. OVERLAY) SEE NOTE 6



NOTES:

- Type "A", "B" & "C" trenches require (2) two cuts: first cut initial trench width then 30 days after work has been completed it shall be saw cut 12" wider both sides.
- Type "A", "B" & "C" trenches require placement and maintenance of temporary pavement (sc-800 cold mix) for a minimum of 30 days prior to permanent paving.
- Structural thickness shown is minimum allowable. Other thickness of structural sections may be required by director if existing structural section exceeds these minimums.
- All trench work 5' and deeper shall have approved trench sloping or shoring plan.
- Paving surface at trench joints shall be sealed with asphalt emulsion 4" each side of joint after final compaction of asphalt concrete. Sealant shall be sanded as necessary to prevent traffic pickup.
- Contact Sutter County Public Works (822-7450) 24 hrs. prior to trenching.
- Contractor shall provide S.E. (Sand Equivalent) test Results for backfill and bedding material from geotech lab.

8. All trenches in the public R/W shall be either properly backfilled or sealed w/steel plates at the end of each working day.

DATE	REVISIONS	BY
6/22/04		K.X.

COUNTY OF SUTTER

DRIVEWAY CONNECTION

APPROVED COPY ON FILE 3/14/06

APPROVED DATE

SCALE: NONE DWG NO. H-28

DRN: PSO

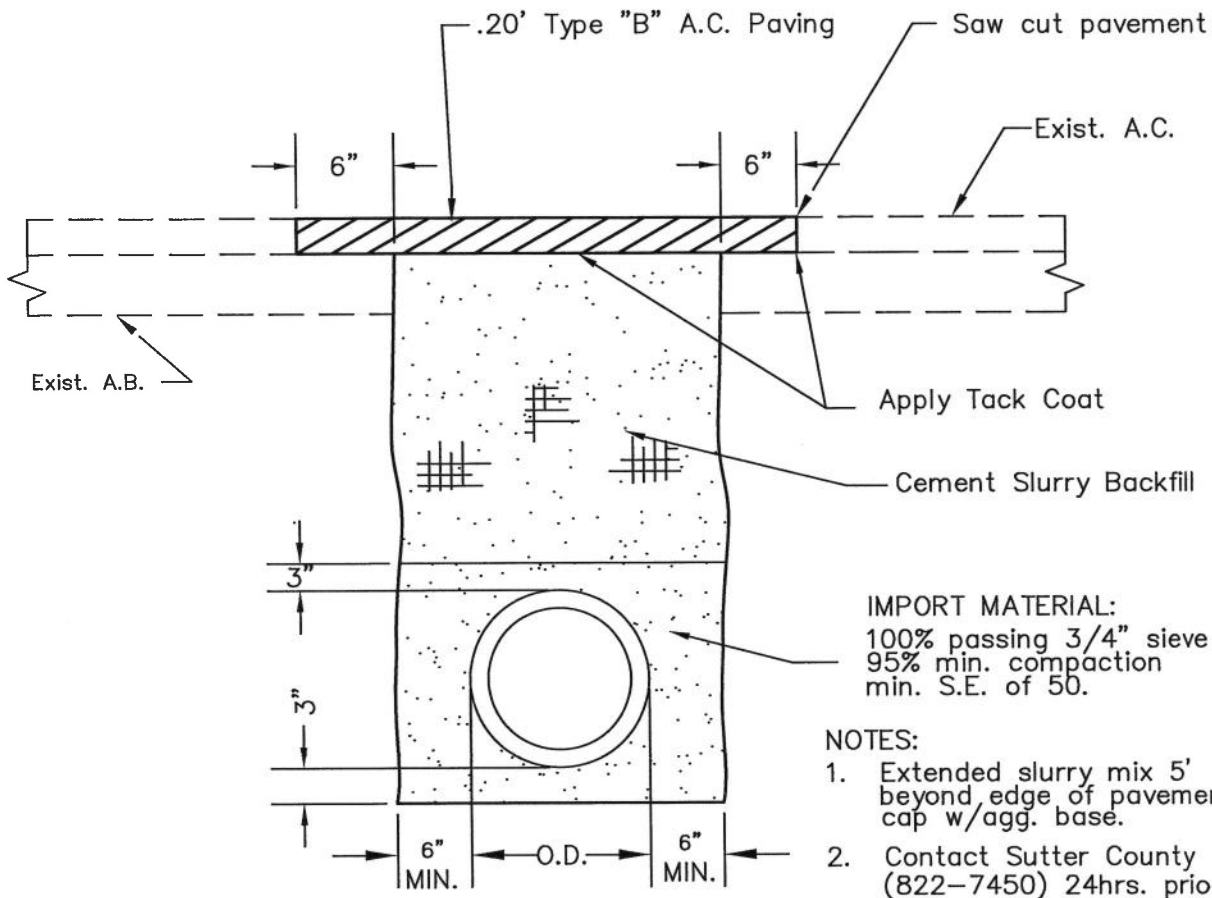

TYPE II TRENCH RESTORATION

CEMENT SPECIFICATIONS

- 2 Sack Portland Cement (188 lbs.)
- 52 Gallons Water
- 814 lbs. 3/8" rock SSD Weight
- 2310 lbs. Sand

TOTAL BATCH WT. 3,750 LBS. PER CUBIC YARD ±10% TO BE SHOWN ON DELIVERY TICKET.

Backfill Slurry mix to top of exist. a.b. and bridge w/metal plate until slurry mix can support vehicular traffic.
 Asphalt concrete patch to match existing thickness, 0.2' min.
 Do not move slurry once placed in ditch.
 2% max. (by cement wt.) calcium chloride may be added to slurry mix.

COUNTY OF SUTTER	
TYPE II TRENCH RESTORATION	
APPROVED COPY ON FILE	3/14/06
APPROVED	DATE
SCALE: NONE	DWG NO. H-29A
DRN: PSO	

6/22/04		K.X
DATE	REVISIONS	BY

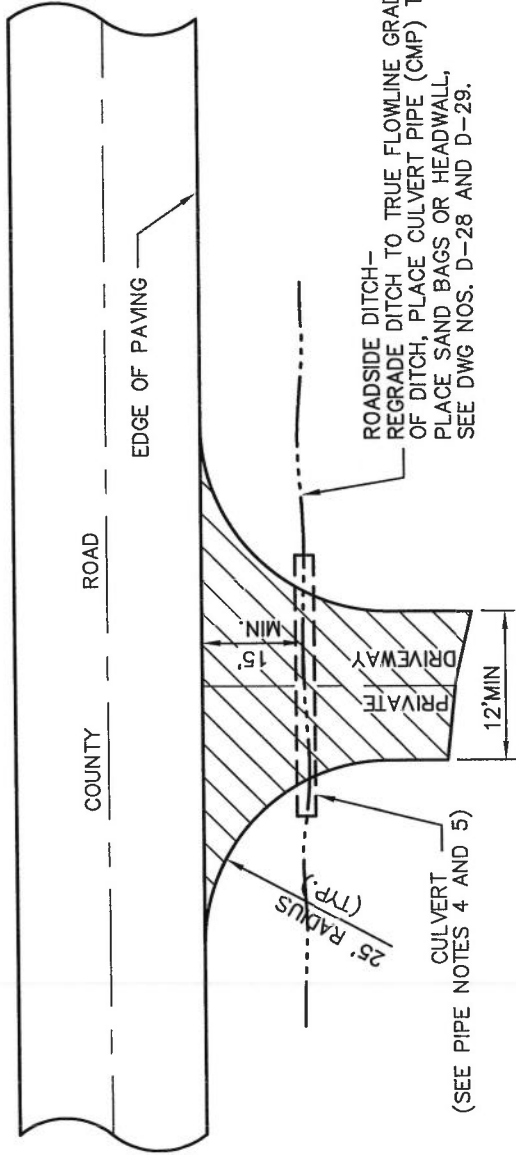

NOTE:

1. Pipe shall be placed slightly below existing grade or at a grade specified by the County Road Department.
2. Pipe sections shall be joined together securely to prevent infiltration.
3. Used pipe is unacceptable.
4. Pipe diameter shall be 12" minimum.
5. Pipe placement shall be 100' maximum in length. Any pipe placement more than 100' in length shall install a DI or leave 5' gap between.

NOTES:

1. Prior to new paving, edge of existing paving at County road is to have a neat, straight, vertical sawcut to tie into.
2. Prior to placing asphalt concrete the sawcut edge is to have a SS-1 tack coat applied.
3. The driveway approach section shall be a minimum of 2 1/2" asphalt concrete on 4" Class II aggregate base rock for residential approaches and 4" asphalt concrete on 6" Class II aggregate base rock for commercial drive approaches. Asphalt concrete shall consist of AR4000, 1/2" maximum aggregate asphalt concrete. Base rock shall be compacted to 95%.
4. Asphalt concrete placement at County road is to be a flush butt joint. Placed to sawcut edge of road and sloped away from road.
5. Finish grade is to slope away from County road at a minimum 2% fall, 5% maximum fall.
6. Paving surface at butt joints shall be sealed with SS-1 emulsion 4" each side of joint after final compaction of asphalt concrete. Sealant shall be sanded as necessary to prevent traffic pick up.
7. All work shall conform to the Standard Specifications of the State of California, Department of Transportation, current edition.
8. Public Works shall be notified 24 hours after permit issue and prior to any work performed. Phone Number 822-7450
9. No additional drainage water direct to County right of way. Appropriate agencies shall be contracted/notified of work prior to any work start for necessary utility permits and USA notification (1-800-227-2600) and markings by permittee/owner.

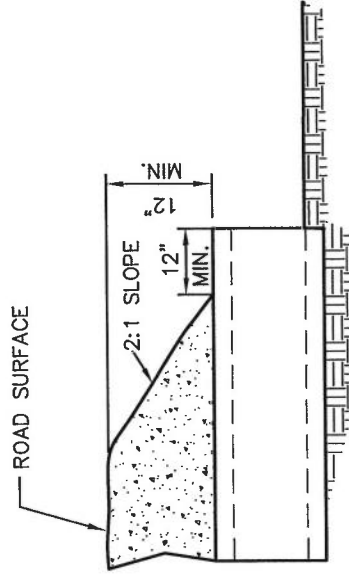

CULVERT DETAIL

COUNTY OF SUTTER

DRIVEWAY CONNECTION

APPROVED COPY ON FILE _____ DATE 3/14/06

SCALE: NONE
DRN: PSO

DWG NO. H-12

BY KSX

REVISIONS

DATE 3-12-08

#4 REBAR

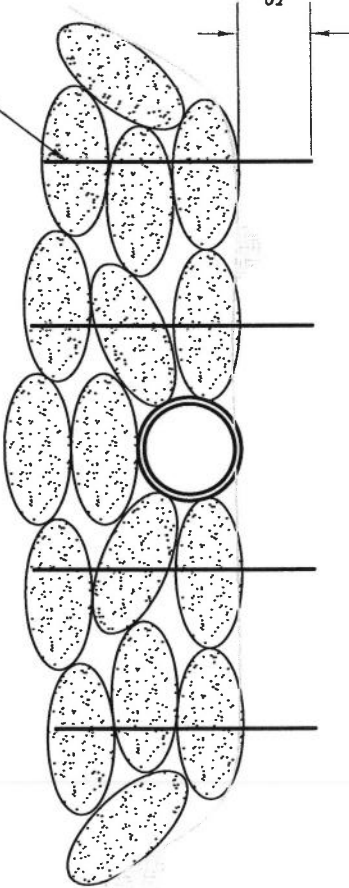

SEE NOTE 4.

12" MIN.

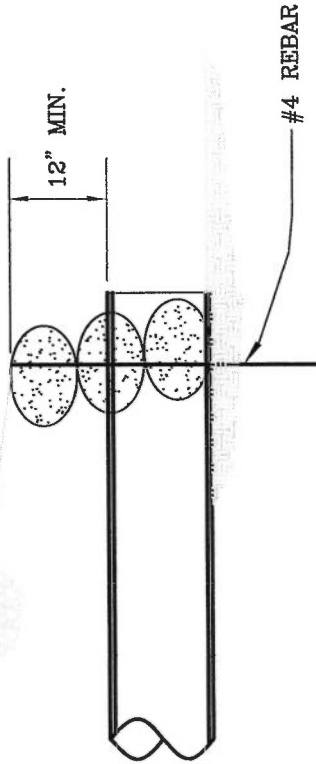

SIDE VIEW

NOTES:

1. PIPE SHALL BE PLACED SLIGHTLY BELOW EXISTING GRADE.
2. BACKFILL REQUIREMENT FOR PRIVATE ROAD AND DRIVEWAY CONNECTION, SEE DWG NOS. H-12 AND H-13.
3. REBAR SHALL CUT OFF A MINIMUM ONE INCH BELOW THE SURFACE.
4. REBAR SHALL PENETRATE INTO THE GROUND AS REQUIRED TO SECURE THE SAND BAGS IN PLACE OR AS DIRECTED BY INSPECTOR.

COUNTY OF SUTTER

SANDBAG

APPROVED COPY ON FILE _____ 3/14/06
APPROVED DATE

SCALE: NONE DWG NO. D-28A
DRN:

DATE	REVISIONS	BY

NOTES:

1. "L" MAY BE REDUCED IF REQUIRED BY CHANNEL DIMENSIONS.
2. REINFORCING BAR (REBAR) SPACING SHOWN IS MAXIMUM SPACING.
3. ALL REBAR CLEARANCE SHALL NOT BE LESS THAN 2" UNLESS SPECIFIED.
4. "•" THESE REBARS ARE REQUIRED IF THE WALL HAS NO FOOTING OR FOOTING LESS THAN THE REQUIREMENT.
5. SLOPE AND TOE OF SLOPE INTERSECTION MAY BE ADJUSTED IF REQUIRED BY SITE CONDITIONS AND AS DIRECTED BY INSPECTOR.
6. USE CLASS "B" CONCRETE

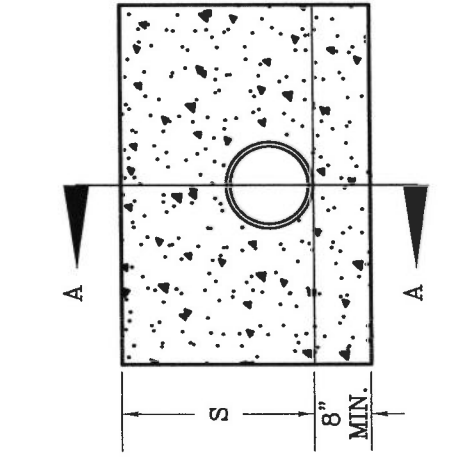

SECTION A-A
NTS

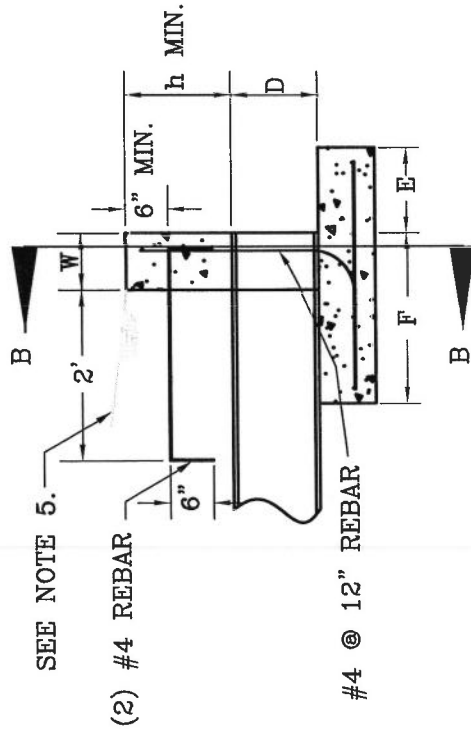

SECTION B-B
NTS

PIPE D	WALL L	WALL H	WALL S	WALL W	FOOTING F	FOOTING E	PIPE COVER h
12"	4'	2'-8"	2'	6"	2'	1'	1'
15"	6'	3'-2"	2'-6"	8"	2'	1'	1'-3"
18"	7'	3'-8"	3'	8"	2'	1'	1'-6"
24"	9'	4'-2"	3'-6"	8"	2'	1'	1'-6"
30"	11'	4'-8"	4'	8"	2'-3"	1'	1'-6"

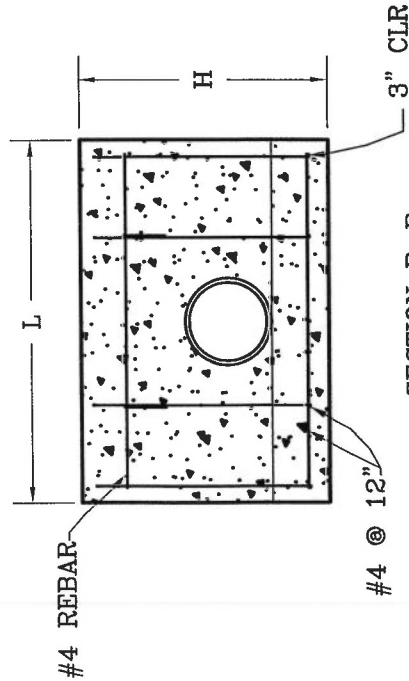

SECTION B-B
NTS

COUNTY OF SUTTER

HEADWALL DETAIL

APPROVED COPY ON FILE 3/14/06 DATE
APPROVED _____ DATE

SCALE: NONE
DRN: _____ DWG NO. D-28

DATE _____ REVISIONS _____ BY _____